

AUTOMATIC SOLAR GARDEN DRIP IRRIGATION SYSTEM

Designed for garden irrigation

Item No.: DS-IRRIGATE

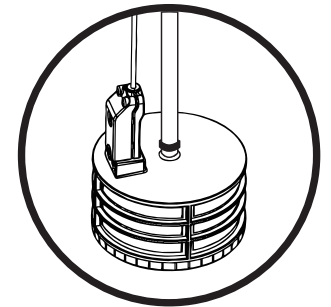
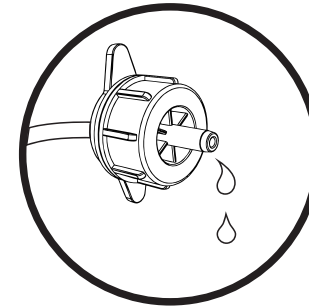
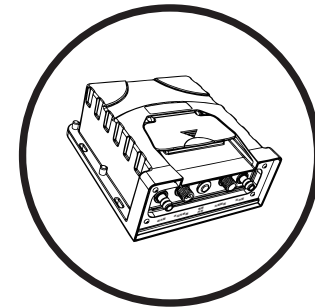
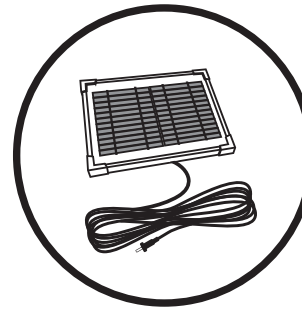

1. OVERVIEW





- 1) The automatic solar garden drip irrigation system is designed for home gardening use, it is suitable for the irrigation of home grown ornamental plants and vegetables. The system is powered by solar energy. The solar panel needs to be placed in the sunlight with its solar cells facing the sun as much as possible.
- 2) There are fifty drippers available and each or several drippers can take care of one plant.
- 3) The system automatically irrigates the plants twice a day for a certain minutes when solar panel feels the sun light in the morning and feels the darkness in the evening.
- 4) There are 5 working modes available differentiated by working minutes per watering to cater various needs from different types of plants, weathers, seasons and soils. The volume of the water irrigated per watering session is proportional to the working minutes.

2. COMPONENTS

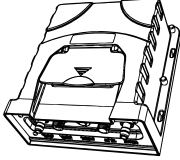
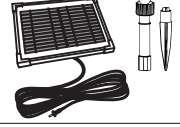

7. TECHNICAL DATA

Maximum quantity of drippers connected	50 PCS
Minimum quantity of drippers connected	20 PCS
Suitable irrigating area	10 to 20 SQM
Solar panel	4 W / 12 V
Cable length of solar panel	3 M
Battery	Ni-Mh, AA 1500 mAh, 7.2 V
Operating voltage	7.2 V
Pump pressure	0.4 Mpa
Max. daily watering volume per dripper	0.67 Liters per day
Max. daily watering volume all drippers	21.3 Liters per day

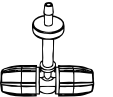
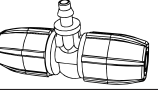
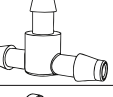
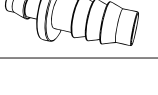
Part No.	Description	Specs	Quantity	Schematic
1	Control unit		1	
2	Solar panel with cable and ground spike	4W / 12V	1	
3	Filter		1	
4	Water level detector		1	
5	Dripper	2L/H	50	
6	Earth rod	10CM	50	
7	Siphon breaker		1	
8	Tee reducer	Φ8MM - Φ4MM	5	
9	Tee distributor	Φ4MM	50	
10	End cap	Φ8MM / Φ4MM	6	
11	Water intake hose	Φ8MM / 2M	1	
12	Main supply hose	Φ8MM / 7M	1	
13	Distribution hose	Φ4MM / 48M	1	
14	Installation pieces		1 set	

3. INSTALLATION

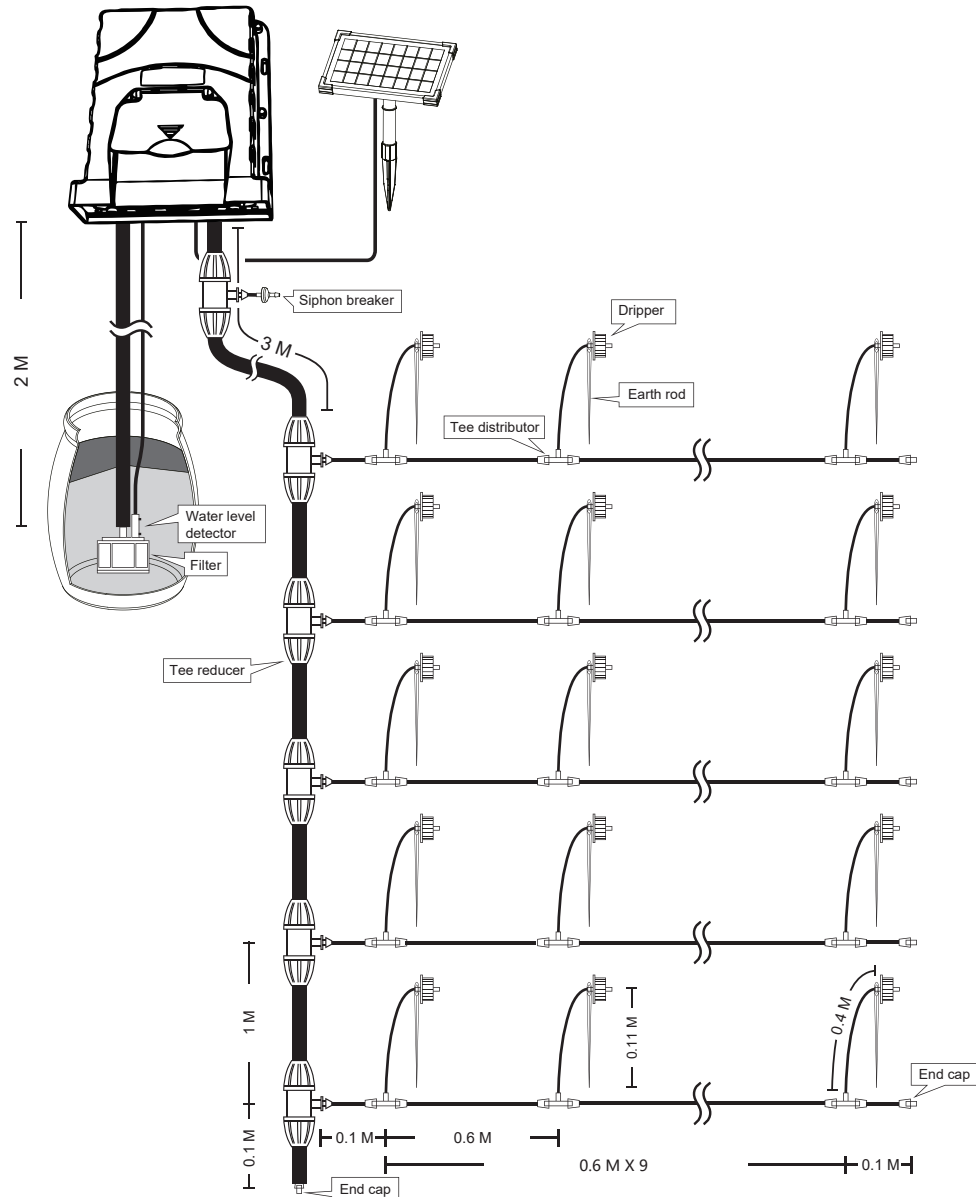

Figure 1

6. MAINTENANCE AND TROUBLE SHOOTING

- 1) If the **ALARM** indicator flashes **Red**, fill the reservoir (Referring to **Figure 12**).

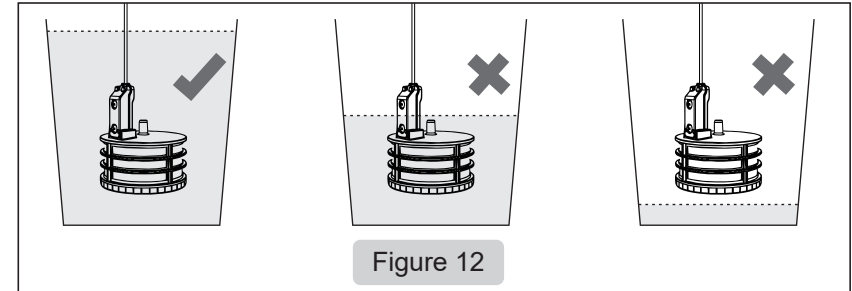

Figure 12

- 2) To ensure the system works reliably and robustly, check and clean the water level sensor and filter after a period of operation as shown in **Figure 13**.
- 3) If there is no water coming out of a dripper, check and clean all parts of the dripper as shown in **Figure 14**.
- 4) If the working minutes per watering session fall short of the setting value, replace the battery that is exhausted with a new one (Referring to **Figure 15**).
- 5) If the battery is not charged in the day time of a sunny day (**CHARGING** indicator does not light), check the electrical connection to the solar panel and make sure the solar panel has full exposure to the sun light.

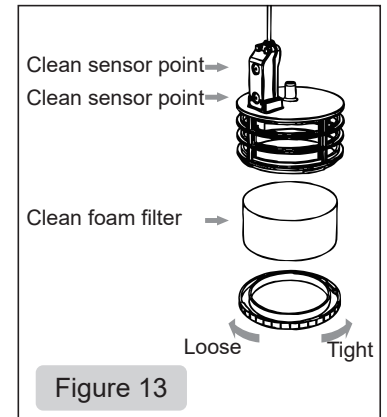

Figure 13

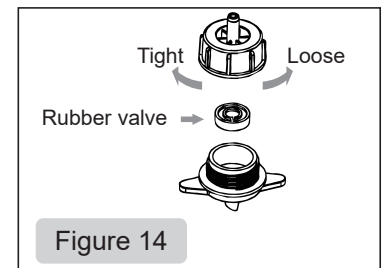

Figure 14

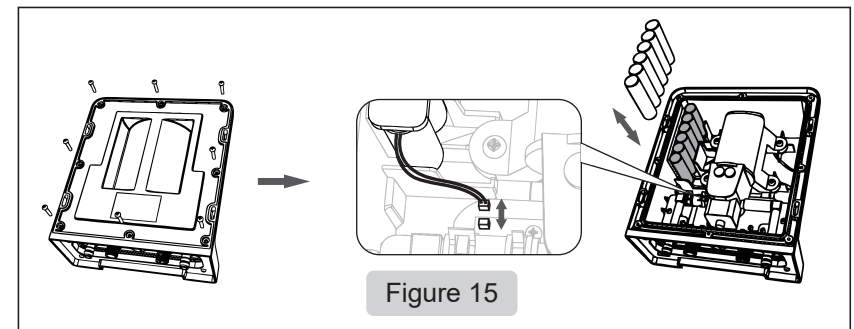

Figure 15

- 5) The **CHARGING** indicator lights in **Yellow** when battery is being charged by the solar panel.
- 6) When the water level detector is no long in water, the **ALARM** indicator flashes **RED** and the pump stops running. Fill the reservoir with some water.
- 7) The solar irrigation system is now ready to operate.

Average daily watering volume vs. number of drippers and working modes

Mode \ Drippers	0.5 min.		1 min.		2 min.	
	1 dripper (Liters)	Total (Liters)	1 dripper (Liters)	Total (Liters)	1 dripper (Liters)	Total (Liters)
20	0.042	0.834	0.084	0.833	0.166	3.334
30	0.038	1.150	0.076	2.300	0.154	4.600
40	0.032	1.266	0.064	2.534	0.126	5.066
50	0.026	1.334	0.054	2.666	0.106	5.334
Mode \ Drippers	4 min.		8 min.			
	1 dripper (Liters)	Total (Liters)	1 dripper (Liters)	Total (Liters)		
20	0.334	6.666	0.666	13.334		
30	0.306	9.200	0.614	18.400		
40	0.254	10.134	0.506	20.266		
50	0.214	10.666	0.426	21.334		

5. CAUTIONS

- 1) Any altering of the product itself or changing of the components voids warranty.
- 2) Operate the pump in water only(never above 40°C), especially keep it away from flammable liquids.
- 3) Do not put any unresolvable particles into the water reservoir, the unresolved particles could block the filter.
- 4) Keep the pump in a frost-free place in winter.

- 1) Unpack all components carefully.
- 2) Find an appropriate location for the placement of the control unit. The control unit can be installed **vertically (recommended)** as shown in **Figure 2** or laid flat. Its water inlet on the bottom should be higher than the maximum possible water level of the water reservoir but no more than 2 meters higher than the minimum water level of the water reservoir (referring to **Figure 1: Recommended system installation schematic**). The location should be able to avoid the control unit getting dipped into water when raining.
- 3) Find a sunny place that is shadow-free all day long and install the solar panel by the ground spike. Point the solar panel towards the midday sun to maximize its exposure to the sunlight throughout a day, and then lock the ball joint by tightening the gland nut as shown in **Figure 3** and **Figure 4**.

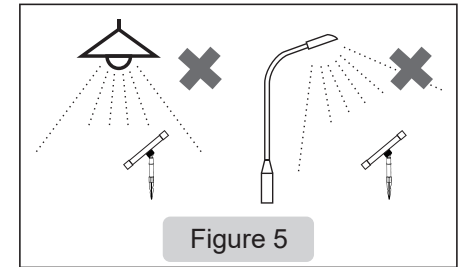
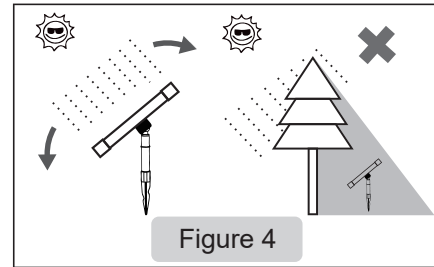
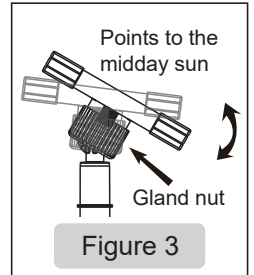
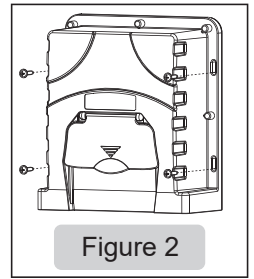

- 4) The solar panel is used as a photosensor to automatically start the system operation twice a day. To avoid misoperation, the solar panel should not be exposed to any other light source except sun light(referring to **Figure 5**).
- 5) Lay the cable on the solar panel without tripping hazards to the control unit. Insert the plug on the cable into the socket on the bottom of the control unit labelled **"INPUT DC 12V"** as shown in **Figure 6**.
- 6) Roll out the 2m water intake hose of 8mm in diameter. Estimate the distance from the control unit water inlet to the bottom of your water reservoir. Cut the hose to a proper length that is long enough to cover the distance. Fit the hose to the water inlet as shown in **Figure 6**. Fit another end of the hose onto the water outlet of the filter.

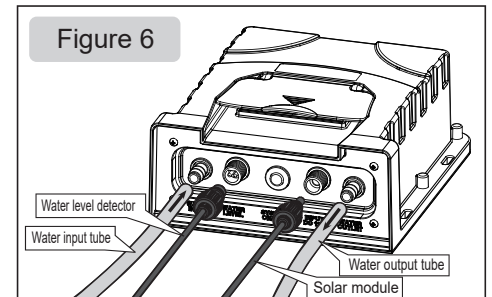

7) Roll out the cable on the water level detector and insert the plug to the socket on the control unit labelled “**WATER LEVEL**” as shown in **Figure 6**.

8) Push the water level detector into the dedicated base on the top of the water filter as shown in **Figure 7** and place the water filter and the attached detector on the bottom of the reservoir.

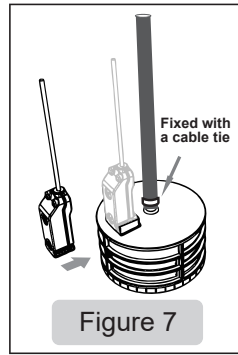

9) Connect any of the two connectors on the siphon breaker to the water outlet on the control unit with a 20cm long hose cut from the main supply hose. Firm the connection between the hose and the water outlet with enclosed self-locking plastic cable tie and the connection between the hose and the siphon connector by tightening the screw nut on the siphon breaker connector as shown in the **Figure 6** and **Figure 8**. When connecting the hose to the siphon breaker, unscrew the relevant screw nut first. Another connector of the siphon breaker serves as an access point for the main water supply line.

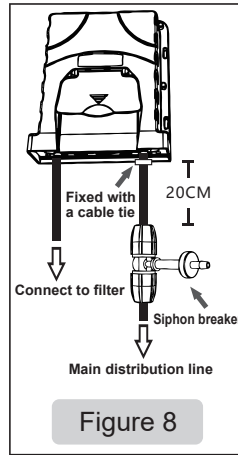

10) Construct the main supply line with the main supply hose and tee reducers as per the layout of the plants as shown in **Figure 9**. Each cluster of plants needs a tee reducer for the relevant water distribution line to access. Up to five tee reducers can be included in the main supply line. Block the end of the main supply line with the end cap enclosed.

11) Install drippers near the plants to be watered with the help of earth rods as shown in **Figure 1**.

12) Construct the water distribution line with distribution hose and T distributors as shown in **Figure 1**. Each dripper needs a T distributor to get access to water.

13) Connect each dripper to the nearby T distributor with a hose cut from the water distribution hose (referring to **Figure 9** a simulation of application system).

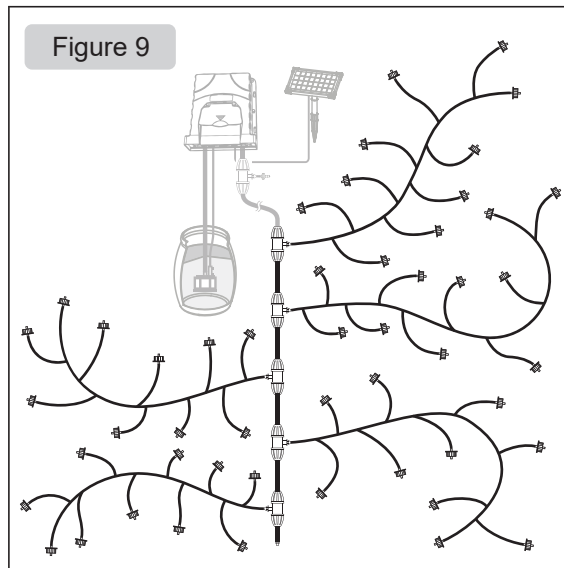

***Note 1:** The system needs at least 20 pcs of drippers connected, otherwise the pressure built up in the water passage may cause over-pressure protection.

***Note 2:** All the hoses are made of plastic, they could be hardened in winter and be difficult to join with connectors and line straight. Soften the hoses by hot water when needed. Hot water brings no damage to the hoses, take care to avoid being scalded. Never heat the hoses with fire.

4. OPERATION

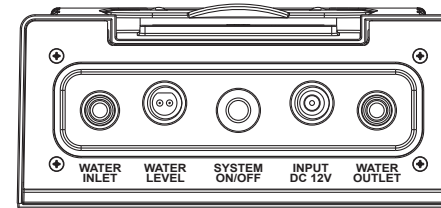

Figure 10

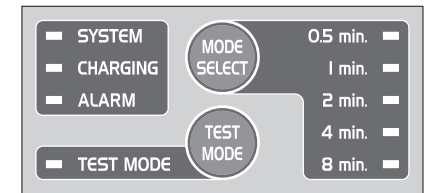

Figure 11

1) Turn on the control unit by the **SYSTEM ON/OFF** switch and the **SYSTEM** indicator on the panel will light as shown in **Figure 10** and **Figure 11**. **SYSTEM** indicator could be in one of the below three colors, proceed only when it is **Green**.

Green: The system is ready for operation.

Yellow: The battery is being charged, and system will be ready for operation within 2 hours.

Red: The battery is flat, it needs to be charged.

2) Press the **TEST MODE** button to test if the system works right. The system will work continuously regardless of the working minutes assigned by the active working mode until user stops the test by pressing the button again as shown in **Figure 11**.

3) Press the **MODE SELECT** button, the indicator of a working mode will flash in **Green**. Repeatedly press the **MODE SELECT** button to roll the flashing **Green** indicator to your desired working mode and stay there. The flashing **Green** indicator will stop flashing in 3 seconds, which means the related working mode is being selected successfully. The working mode can be changed at any time by conducting the same operation.

4) The available working modes differentiated by duration of each watering session are: **0.5 minute, 1 minute, 2 minutes, 4 minutes and 8 minutes**. The system will irrigate the plants twice a day when solar panel feels the sun light in the morning and feels the darkness in the evening for a certain minutes designated by the selected working mode.